

# Tern Cargo Rack

## Tools required for installation: (not provided)

4 mm & 5 mm Allen Wrenches

8 mm & 10 mm Wrenches

## Included in the package

A. Top Deck (with front stays)

B. Left & Right Side Struts

C. Strap

D. 6 X Bolt Sets

E. 4 X Mounting Screws

## Parts:

1. Top Deck Front Fix Point

2. Top Deck Rear Inside Fix Point

3. Top Deck Rear Outside Fix Point

4. Side Strut Legs

5. Side Strut Leg Adjustment Bolt

6. Top Deck Strap Loop

7. Front Stays

8. Front Stay Fix Points

9. Top Deck Front Stay Fix Point Screws

10. Front Stay Fix Point Mount Screws

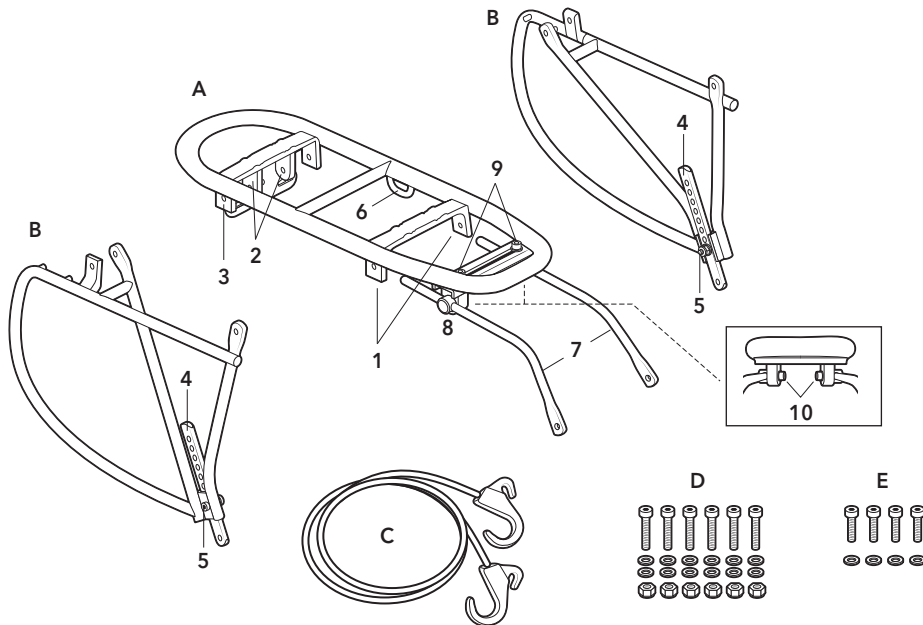
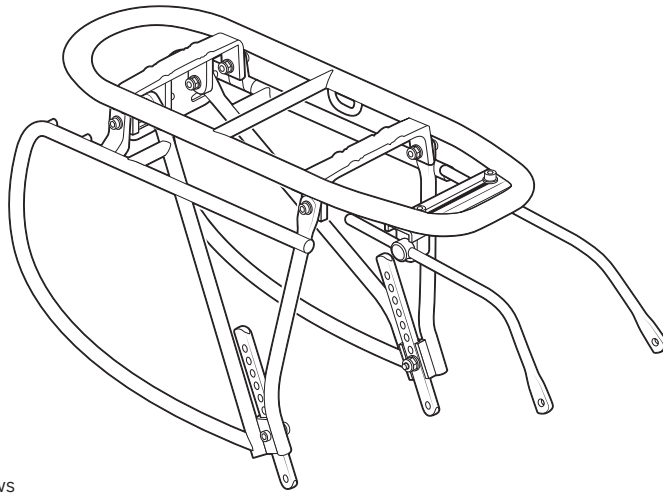

## Assembling the Rack:

### Notes:

- Use 2 Washers for each Bolt: 1 on Bolt Head side and 1 on Nut side.
- Bolts and Screws come with Nylok Blue Patch coating to prevent loosening. If the Nylok becomes worn (no distinct friction when tightening the bolt), apply Loctite 222. Be sure to allow the Loctite to cure.
- Fit nuts locking-round side out /flat side in.

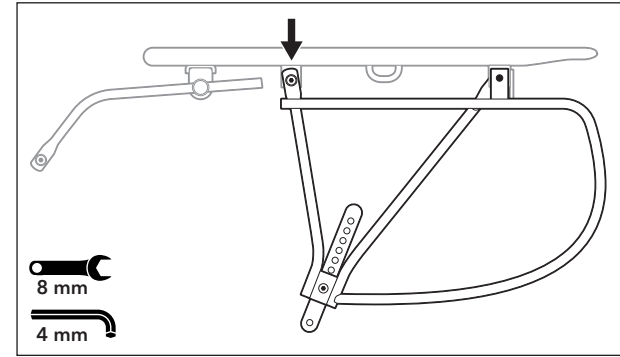

1. Bolt front of the first Side Strut to Top Deck Front Fix Point. (5.5 - 6 Nm.)

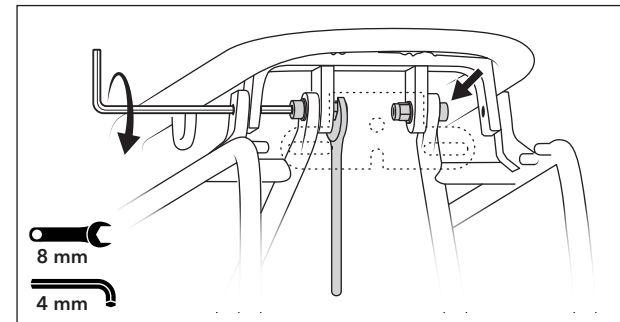

2. Bolt rear inside mount of Side Strut to Top Deck Rear Inside Fix Point. (5.5 - 6 Nm.)

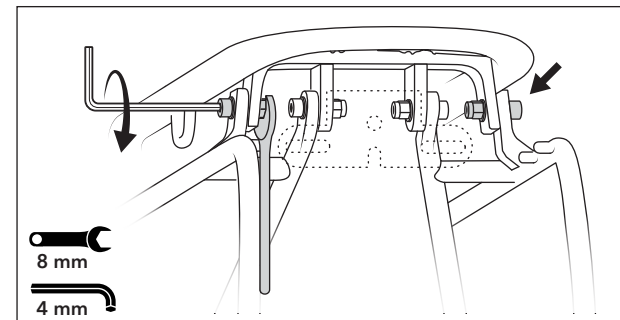

3. Bolt rear outside mount to Top Deck Rear Outside Fix Point. (5.5 - 6 Nm.)
4. Repeat steps 1-3 for the second Side Strut.

## Assembling the Rack (continued)

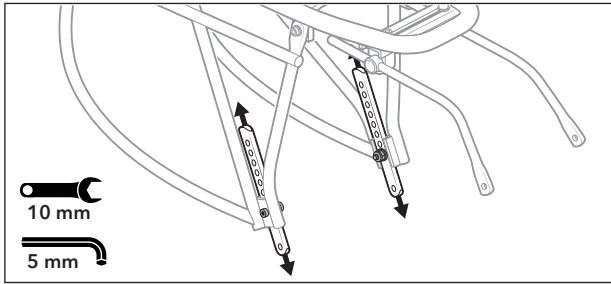

5. Adjust the length of the Side Strut Legs to fit your bike and tighten the Adjustment Bolts. (6.5 - 7 Nm.)

## Fixing the Strap

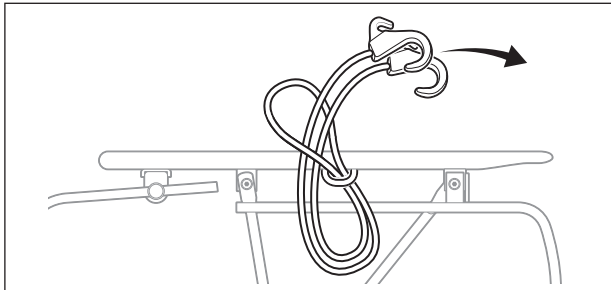

1. Fold the Strap in half, thread it through the Top Deck Strap Loop and pass the Hook Ends through the loop to fix the Strap to the Top Deck.

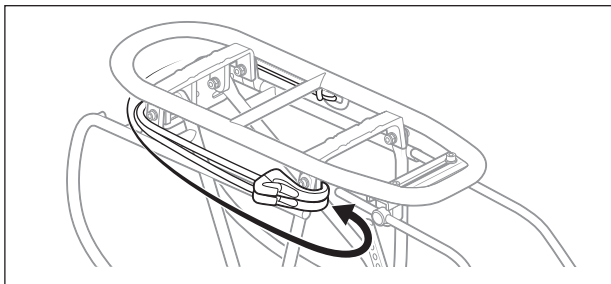

2. Wrap the Strap around the back of the Top Deck and fix the Hook Ends on the front of the opposite Side Strut.

## Mounting on your Bike

**Note:** To better fit the location of the Frame Upper Bosses on different Tern bikes, mount the Front Stays either on the outside or inside of the Front Stay Fix Points.

- For Verge and Eclipse bikes, mount the Front Stays on the INSIDE of the Fix Points.
- For Link and Node bikes, mount the Front Stays on the OUTSIDE of the Fix Points.

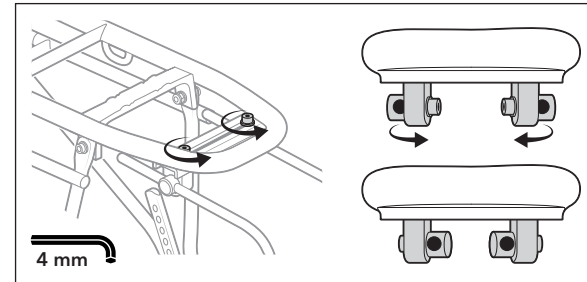

Loosen the Top Deck Front Stay Fix Point Screws and rotate the Front Stay Fix Points to change the side on which the Front Stays are mounted.

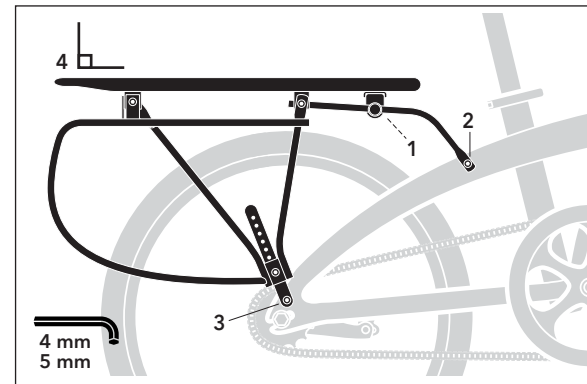

1. Loosen Front Stay Fix Point Mounting Screws to allow adjustment of Stays.
2. Fix Front Stays to Frame Upper Bosses.
3. Fix the Side Strut Legs to the Dropout Eyelets.
4. Level the Cargo Rack and tighten all Mounting Screws. (4 Nm.)

## Internal Cable Routing

Route cables inside the left Side Strut (as seen from back) for connecting power to a rear light.

## Fitting Pannier Bags

Attach side pannier bags to the upper or lower rails of the Top Deck. Stops at the rear of the lower rail ensure pannier bags stay in place. With Side Pannier Bags on the lower rail, you can also attach a bag on the Top Deck.

**LIMITED PRODUCT WARRANTY INFORMATION:** This Product comes with a ONE (1) YEAR Limited Warranty from the date of retail purchase by the original end-user. If a material or workmanship defect arises and a valid claim is received within the Warranty Period, this Product will be replaced. Mobility Holdings cannot be held liable for damages to personal property due to misuse or improper care and maintenance. This Product Warranty does not, under any circumstance, cover the replacement or cost of any third party product used with or connected to the Product.

Tern, the Tern Werd (logotype), and the Tern Berd (device) and Cargo Rack, used alone or in combination are trade names, trade devices or registered trademarks of Mobility Holdings, Ltd.